

# DRAWING FOR CUSTOMER

注释:

- 1.主体:LCP-6808 高温热塑性塑料 UL94V-0;米白色
- 2.推杆: LCP -E471i 高温热塑性塑料 UL94V-0 颜色: 黑色
- 3.端子: C5191 磷青铜  
电镀: 先铜底镀镍50~100u, 在镀1u金或者镀100~150u雾锡(无铅)
- 4.固定片: C2680 黄铜  
电镀: 先铜底镀镍50~100u, 在镀100~150u雾锡(无铅)
- 5.料号编码信息:

**KBF506-XX X S R 260 L 2 A**

Pin No.	Version
包装方式: T:TUBE (管装) R:REEL (卷装) P: PE (袋装)	Mold No. Contacts Type:U:Upper L:Lower R:Right F:Left D:Double
S:SMT	H厚度: 1.0mm=100 1.2mm=120 1.5mm=150 2.0mm=200 2.6mm=260
R:Right Angle V:Vertical	

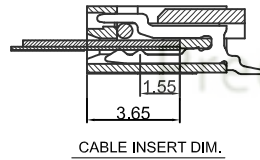
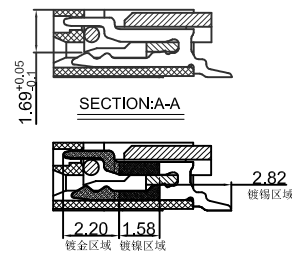
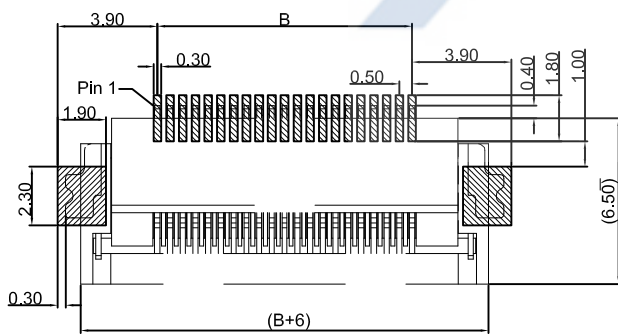
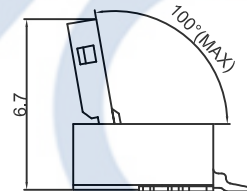
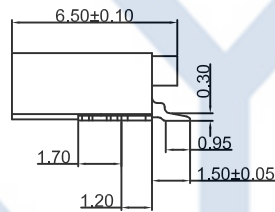
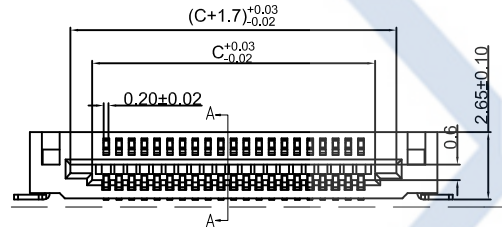
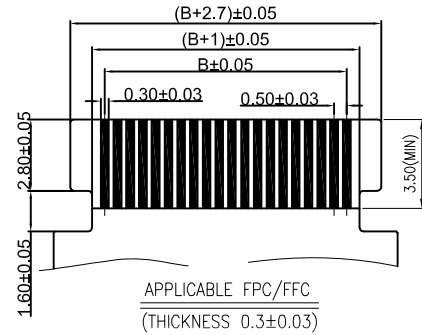
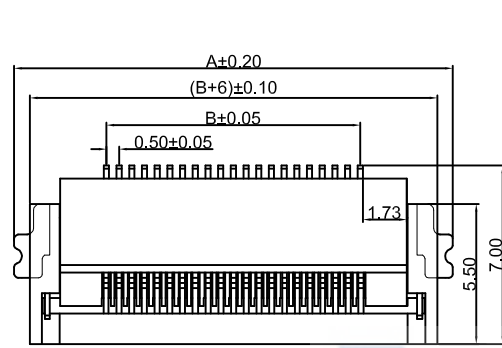

No. of Contacts	Dimension			No. of Contacts	Dimension		
	A	B	C		A	B	C
4	8.50	1.50	2.55	39	26.00	19.00	20.05
5	9.00	2.00	3.05	40	26.50	19.50	20.55
6	9.50	2.50	3.55	41	27.00	20.00	21.05
7	10.00	3.00	4.05	42	27.50	20.50	21.55
8	10.50	3.50	4.55	43	28.00	21.00	22.05
9	11.00	4.00	5.05	44	28.50	21.50	22.55
10	11.50	4.50	5.55	45	29.00	22.00	23.05
11	12.00	5.00	6.05	46	29.50	22.50	23.55
12	12.50	5.50	6.55	47	30.00	23.00	24.05
13	13.00	6.00	7.05	48	30.50	23.50	24.55
14	13.50	6.50	7.55	49	31.00	24.00	25.05
15	14.00	7.00	8.05	50	31.50	24.50	25.55
16	14.50	7.50	8.55	51	32.00	25.00	26.05
17	15.00	8.00	9.05	52	32.50	25.50	26.55
18	15.50	8.50	9.55	53	33.00	26.00	27.05
19	16.00	9.00	10.05	54	33.50	26.50	27.55
20	16.50	9.50	10.55	55	34.00	27.00	28.05
21	17.00	10.00	11.05	56	34.50	27.50	28.55
22	17.50	10.50	11.55	57	35.00	28.00	29.05
23	18.00	11.00	12.05	58	35.50	28.50	29.55
24	18.50	11.50	12.55	59	36.00	29.00	30.05
25	19.00	12.00	13.05	60	36.50	29.50	30.55
26	19.50	12.50	13.55	61	37.00	30.00	31.05
27	20.00	13.00	14.05	62	37.50	30.50	31.55
28	20.50	13.50	14.55	63	38.00	31.00	32.05
29	21.00	14.00	15.05	64	38.50	31.50	32.55
30	21.50	14.50	15.55	65	39.00	32.00	33.05
31	22.00	15.00	16.05	66	39.50	32.50	33.55
32	22.50	15.50	16.55	67	40.00	33.00	34.05
33	23.00	16.00	17.05	68	40.50	33.50	34.55
34	23.50	16.50	17.55	69	41.00	34.00	35.05
35	24.00	17.00	18.05	70	41.50	34.50	35.55
36	24.50	17.50	18.55	71	42.00	35.00	36.05
37	25.00	18.00	19.05	72	42.50	35.50	36.55
38	25.50	18.50	19.55	73	43.00	36.00	37.05

**XYCO** 东莞市轩业电子科技有限公司  
TEL: 0769-8297 9981/2/3 http://www.XYCO.com.cn

2015-07-08		A		KBF506-XXXSR260L2A		Devin		KBF506-XXXSR260L2A	
DATE	VER	CHANGE HISTORY	CHANGED NAME	DRAWING	TOLERANCE 公差	DRAWING 設計者	Devlin	PART NO. 料號	UNIT 單位
日期	版本	變更歷史	修改後料號	變更者	.X=±0.30 .XX=±0.20 .XXX=±0.10	CHECKED 審查	Thomas	DWG NO. 圖號	mm
						APPROVED 核准	William	PE2010001A	PRODUCT NAME 產品名稱

FPC PH0.5mm 前插后掀FPC (H2.6)